

# La lampe PYXAR

Nom de la pièce	Nombre de pièces	Durée d'impression/pièce	Durée d'impression total
<b>Articulation de la lampe</b>			
1 Pivots	3	2130	7130
2 Rivets	3	0123	0145
3 Rondelle	6	0103	0118
4 Poulis	4	1130	6100
5 Roulette	4	0130	2100
<b>Maintien de la lampe</b>			
6 Socle	1	7100	7100
7 Coince câble	1	0130	0130
8 Retenu	1	3100	3100
<b>Mecanisme abat-jour</b>			
9 Tirette	1	2100	2100
10 Glissière	3	0130	2130
11 Anneaux	1	0120	0120
12 Triple Pivot	1	2100	2100
13 Brise-lumière	3	3100	9100
<b>Total</b>			<b>39153</b>

TABLEAU RECAPITULATIF DES DUREES D'IMPRESSION

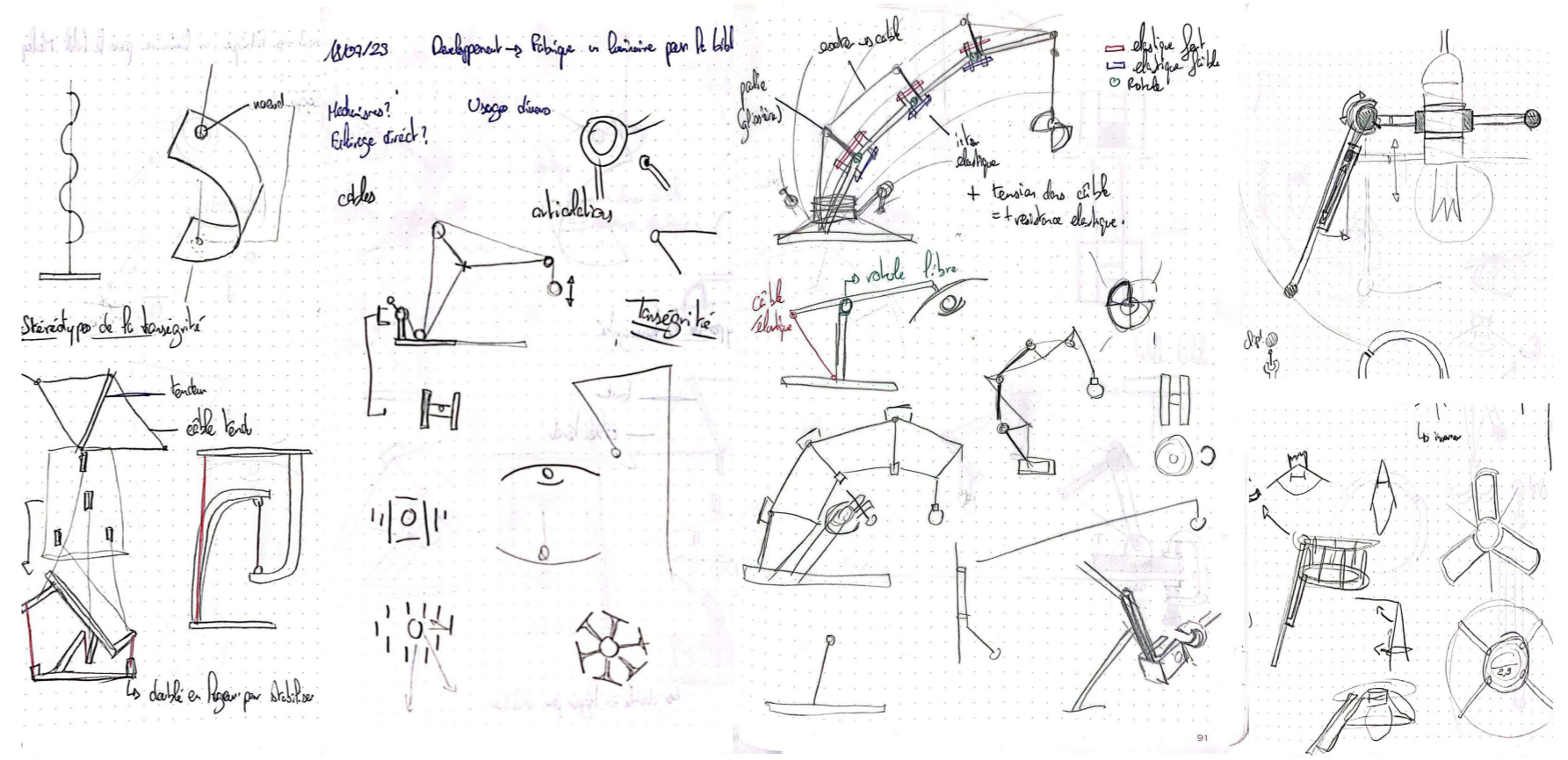

CROQUIS ET PHASE DE RECHERCHE

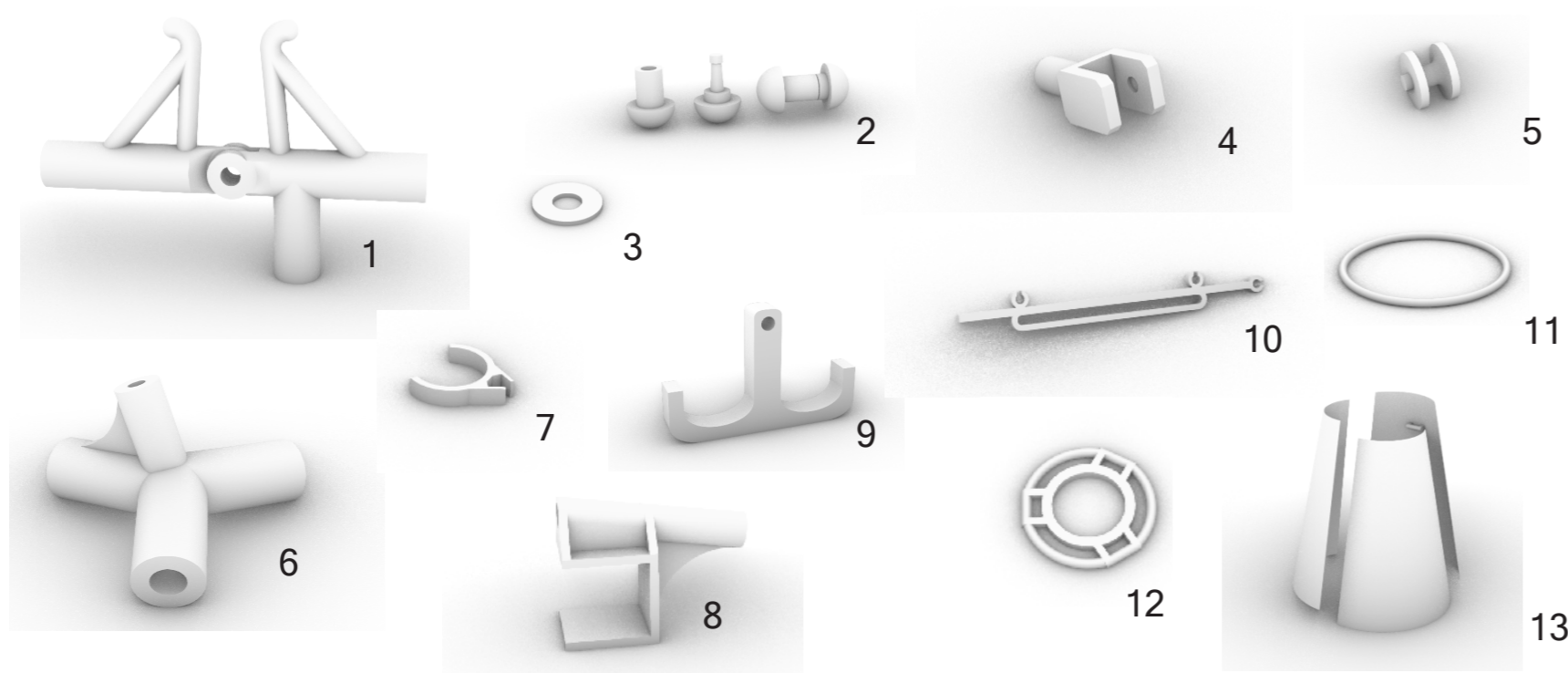

INVENTAIRE DES PIECES IMPRIMES

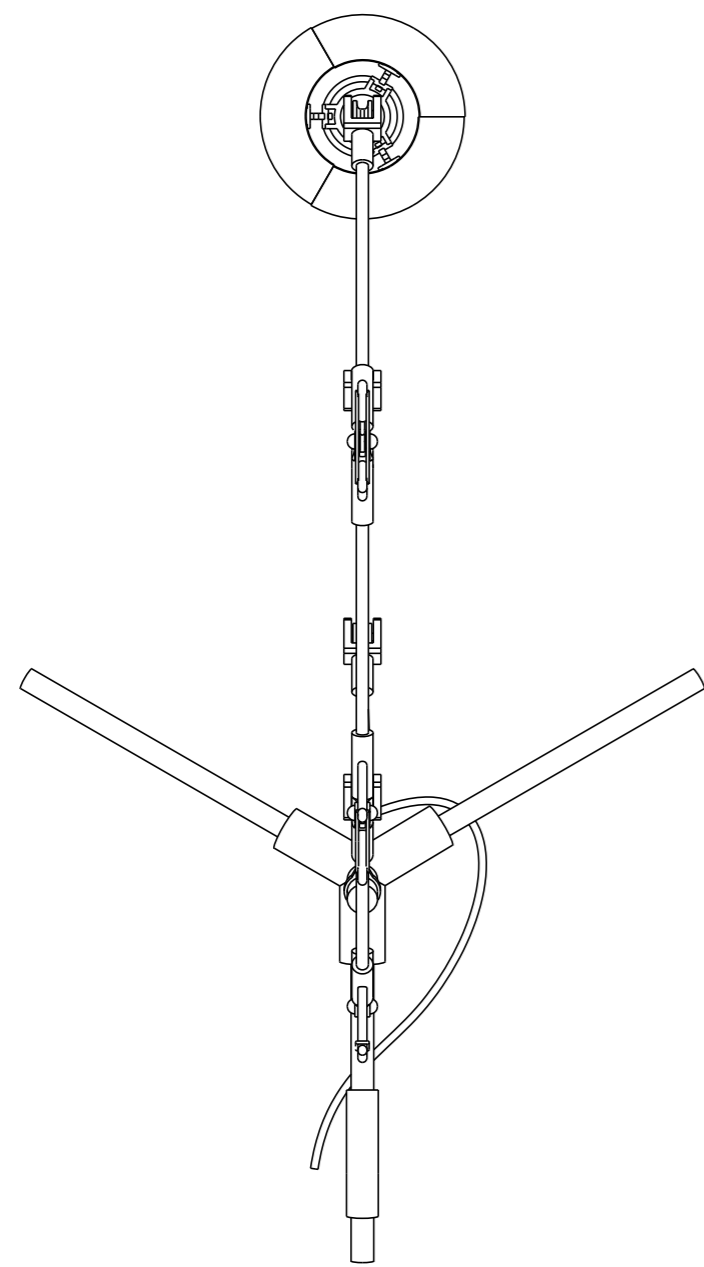

PLAN, ECHELLE 1:5

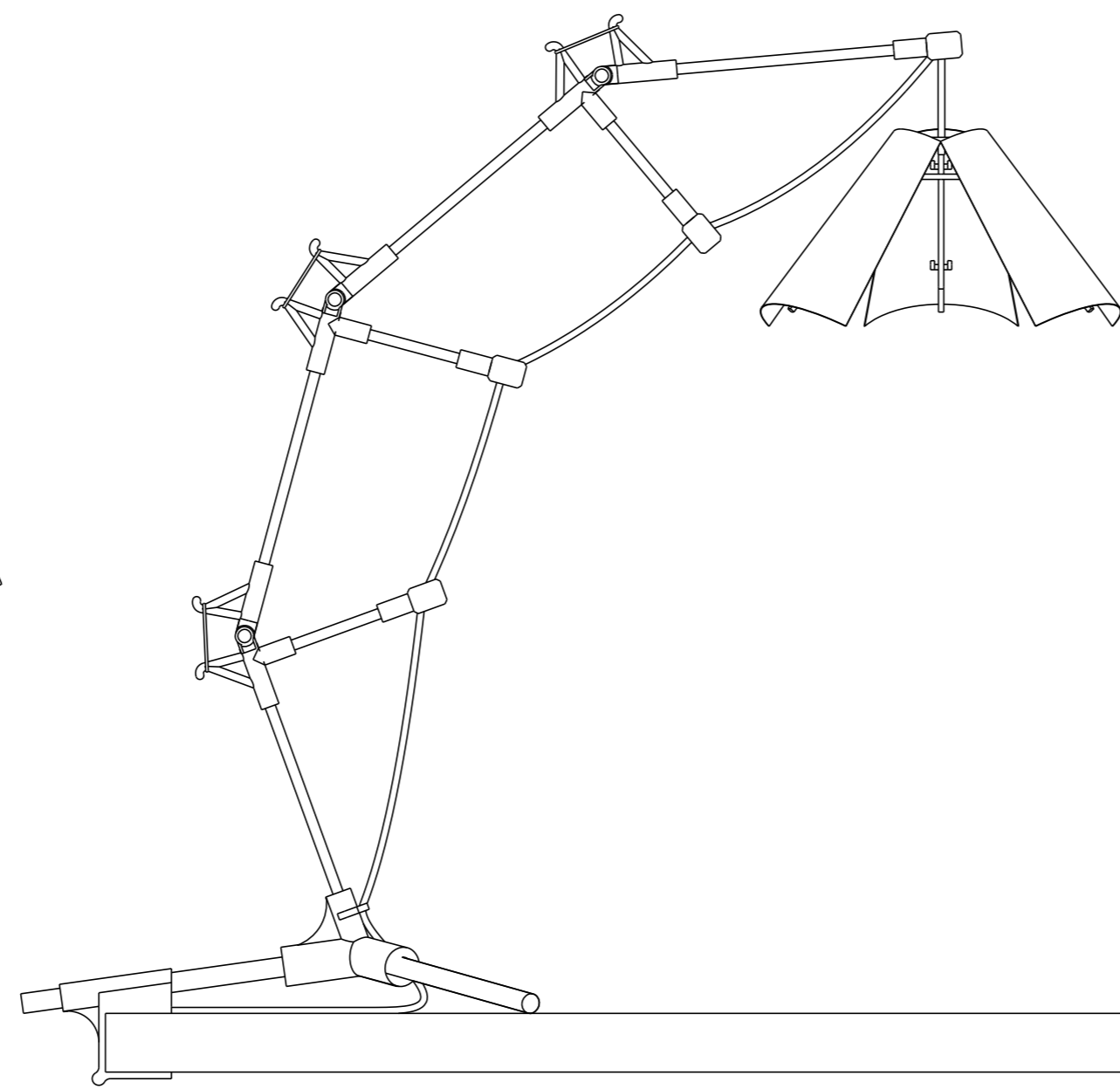

ELEVATION 1, ECHELLE 1:5

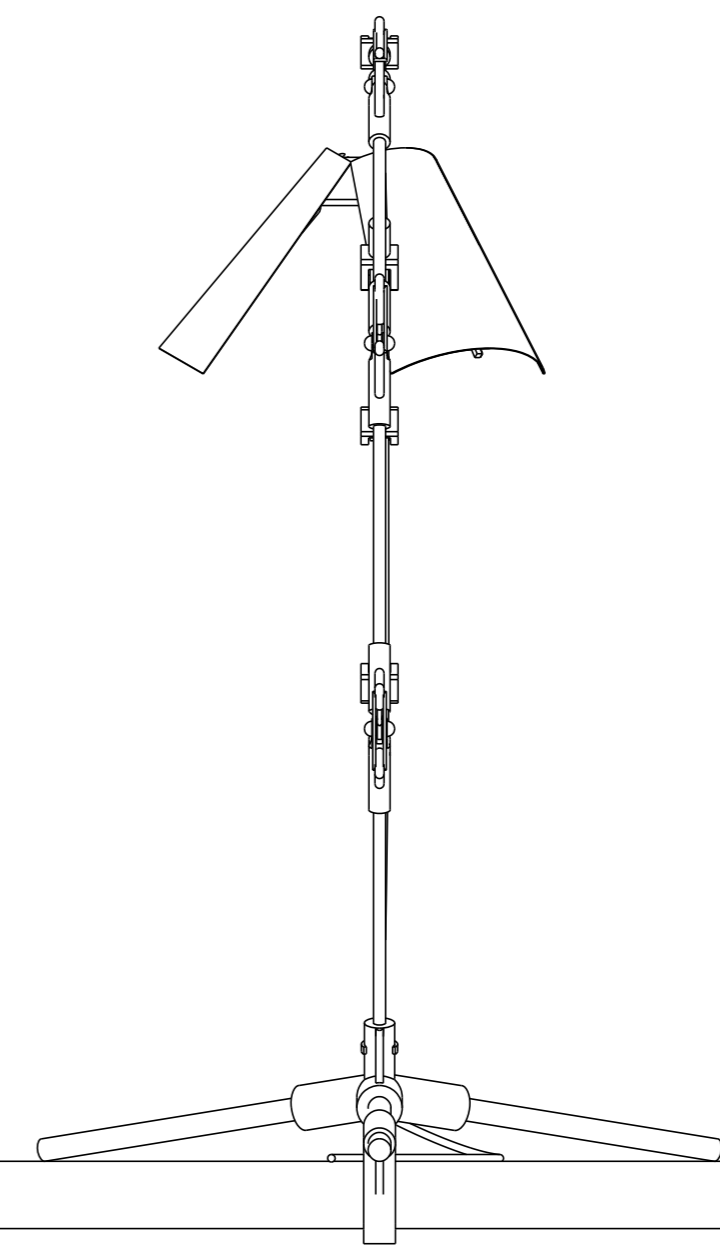

ELEVATION 2, ECHELLE 1:5

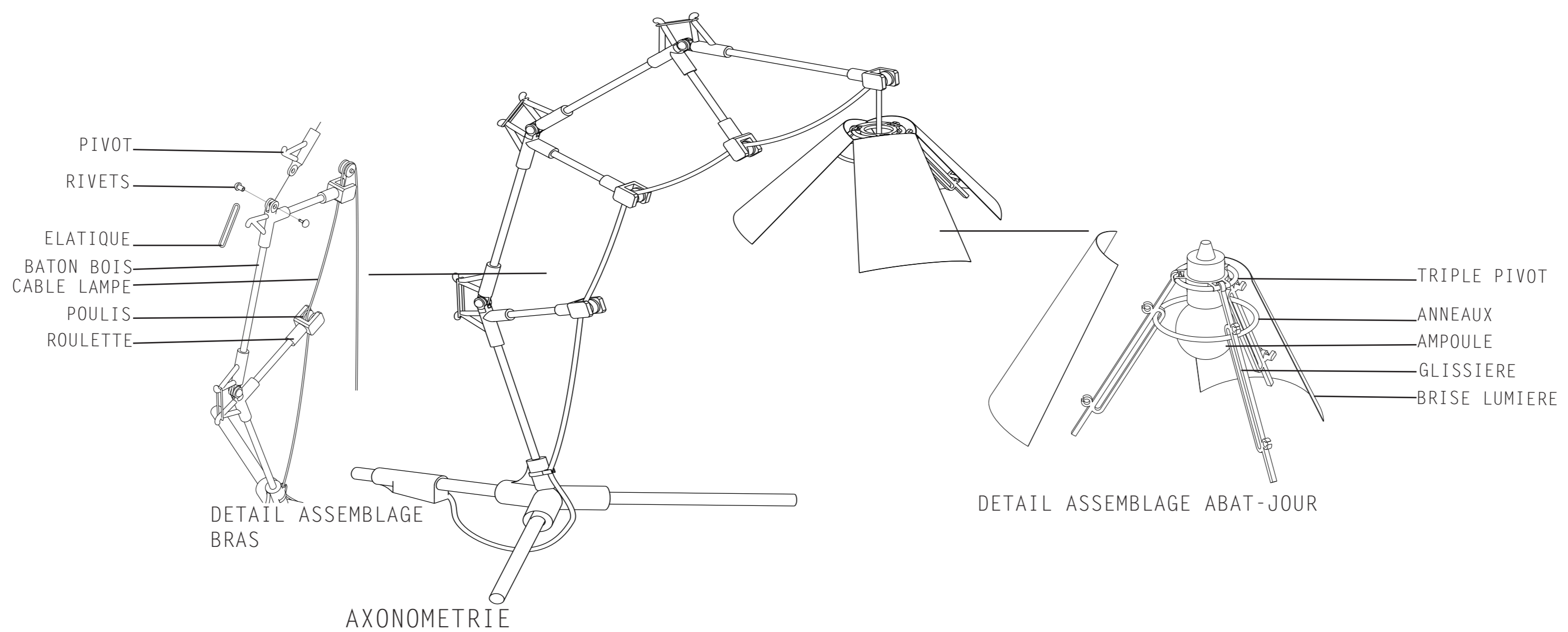

DETAIL ASSEMBLAGE BRAS

DETAIL ASSEMBLAGE ABAT-JOUR

AXONOMETRIE