



École nationale supérieure d'architecture Paris-Malaquais

Print & ReUse



Encadrant : Julien Glath
Monitrice : Lucie Sainrat

Intensifs numériques L3
16-22 septembre 2024-2025

Groupe 4
étudiants : Cleuziou Pavel, Tollimi Amira

Conception



Travail de la forme/couleurs



Differents points de vues observés

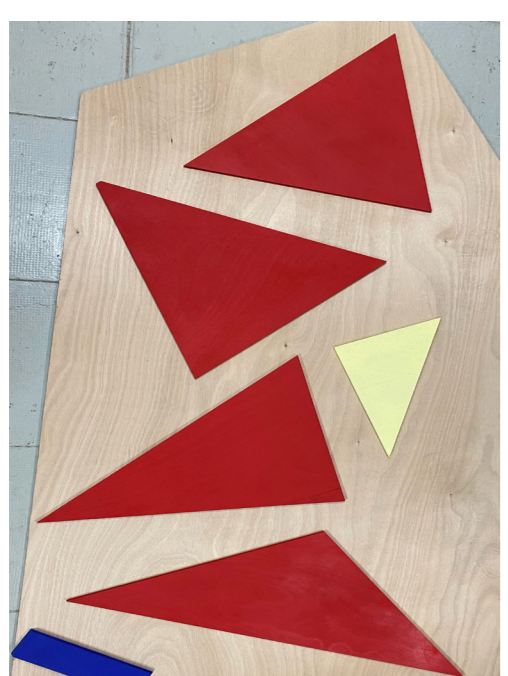

Elements découpés et imprimés

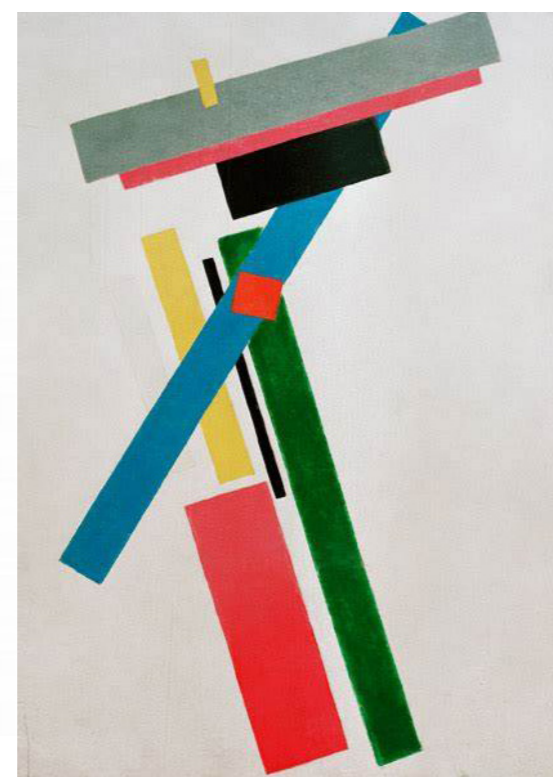

Suprematism 1915,
Kasimir Malevitch
(deconstructivisme russe)

Propagande Communiste

Axonométrie
1:5

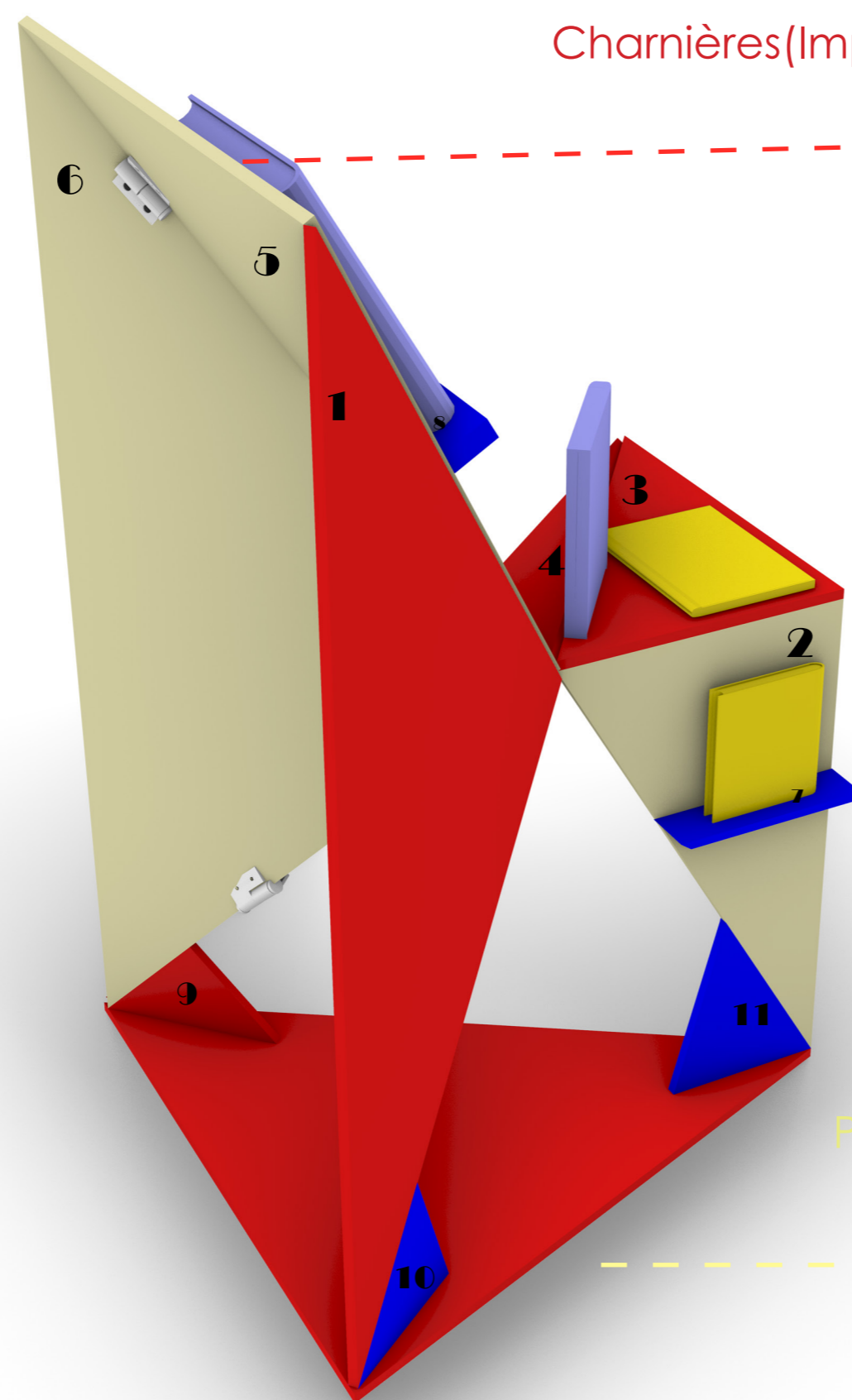

Charnières (Impression 3D)

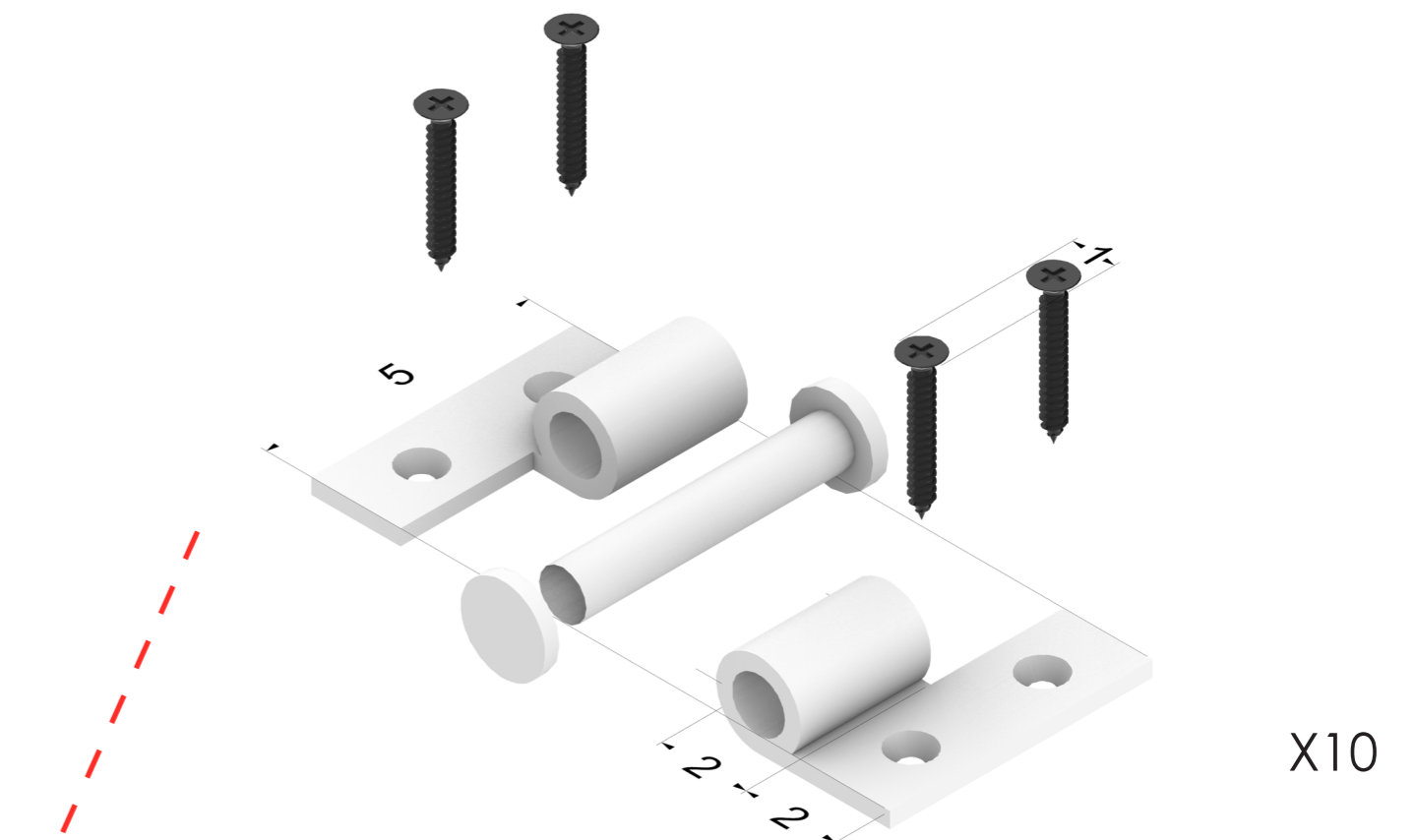

X10

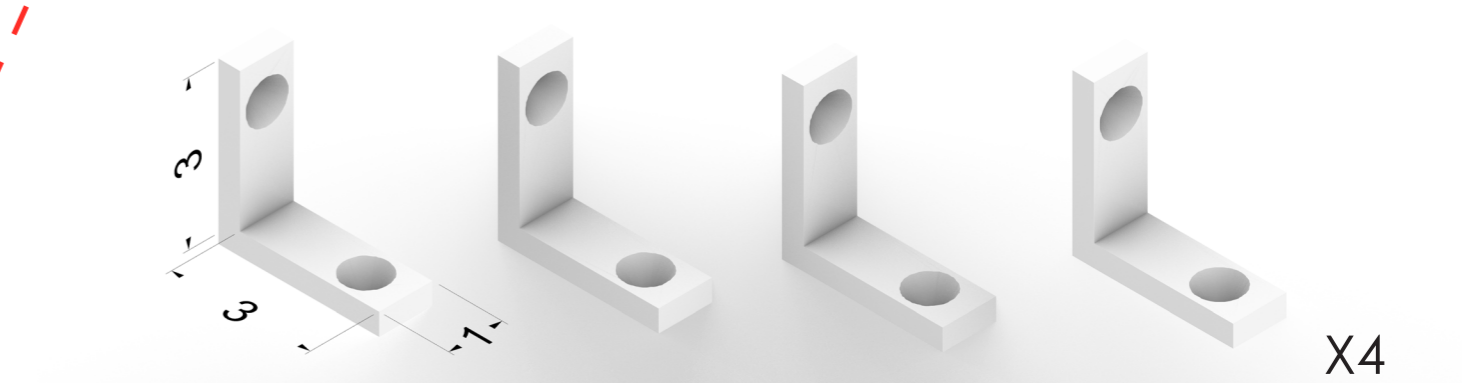

X4

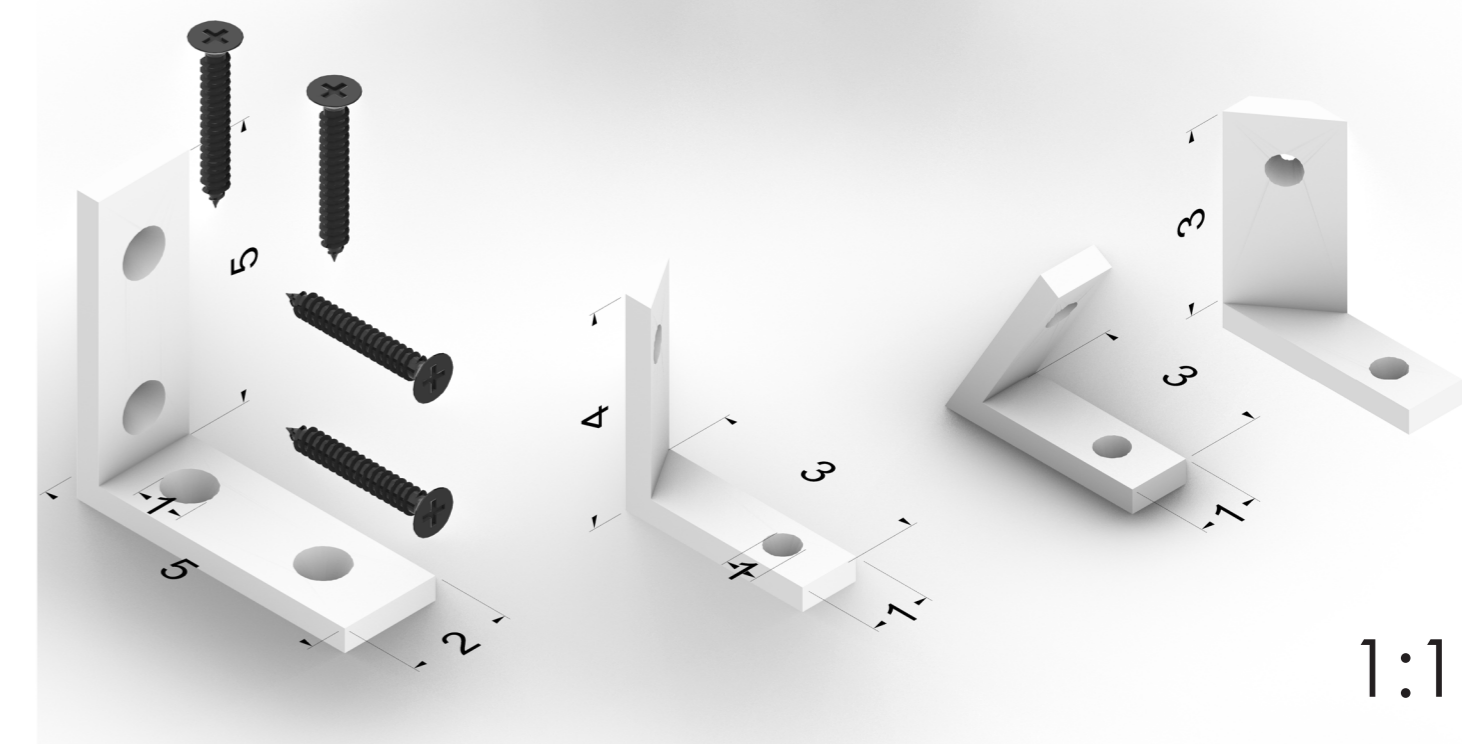

1:1

Planches contre-plaquées (E: 10mm)

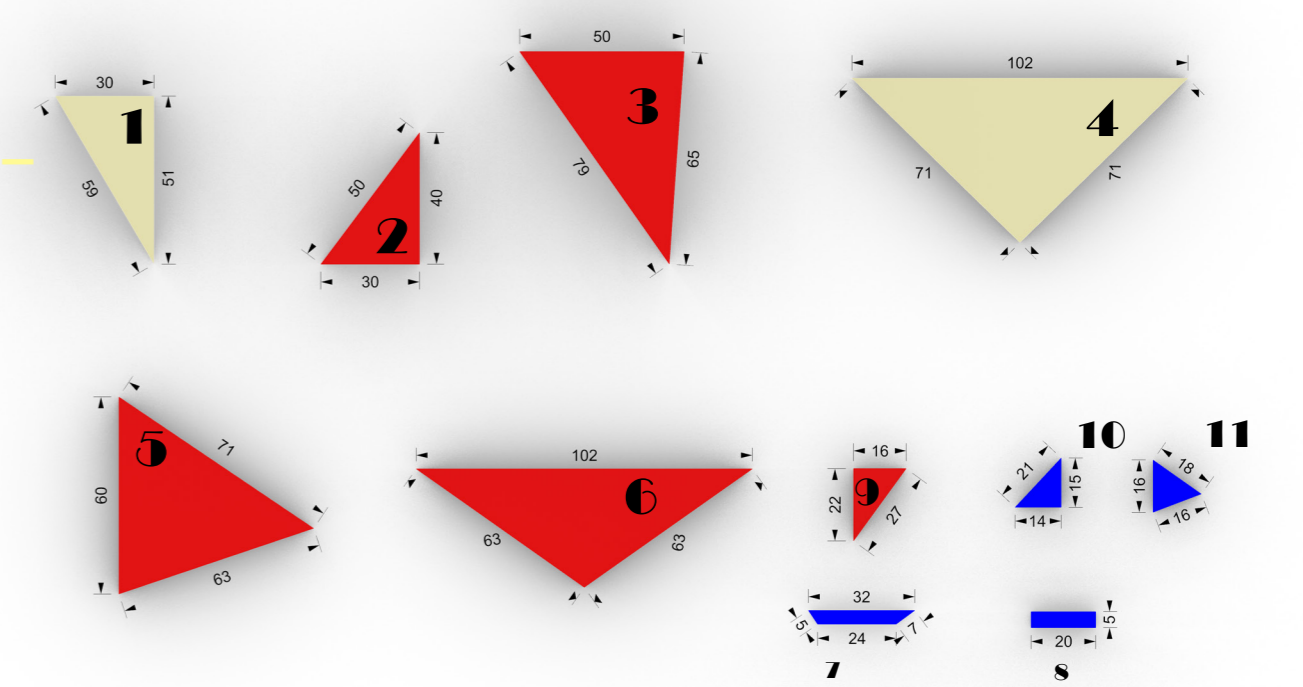

1:20

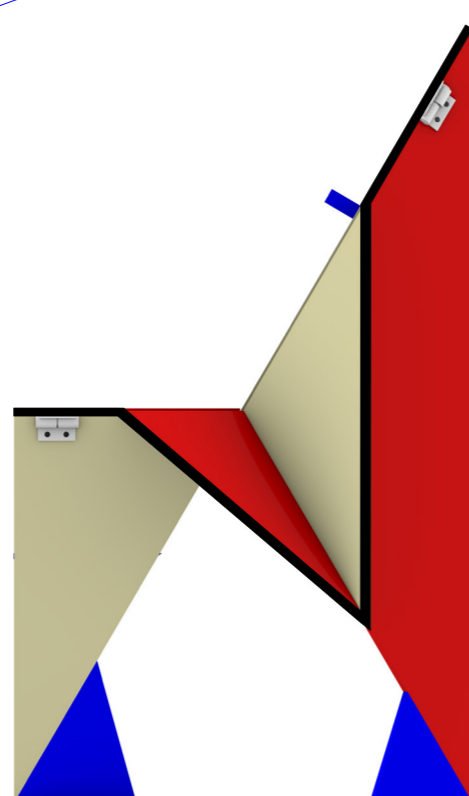
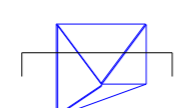

Coupe
1:10

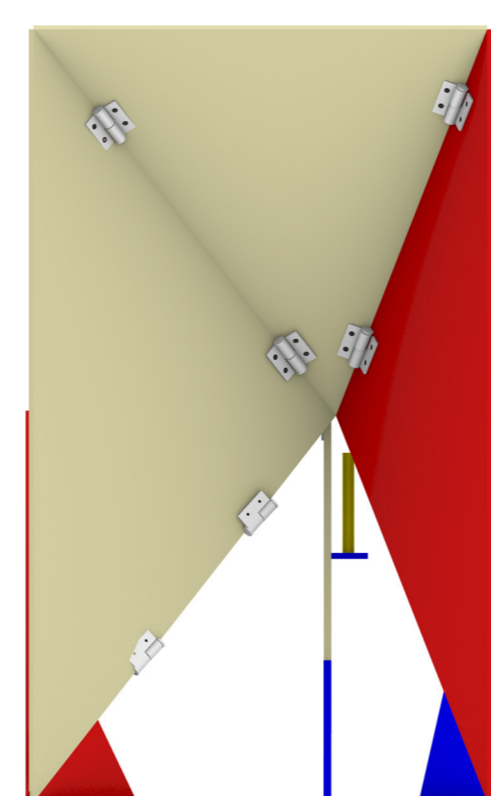
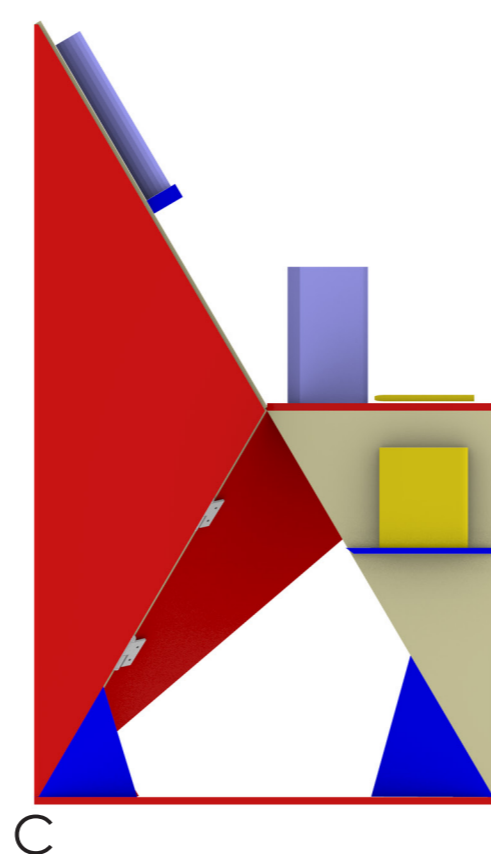

A

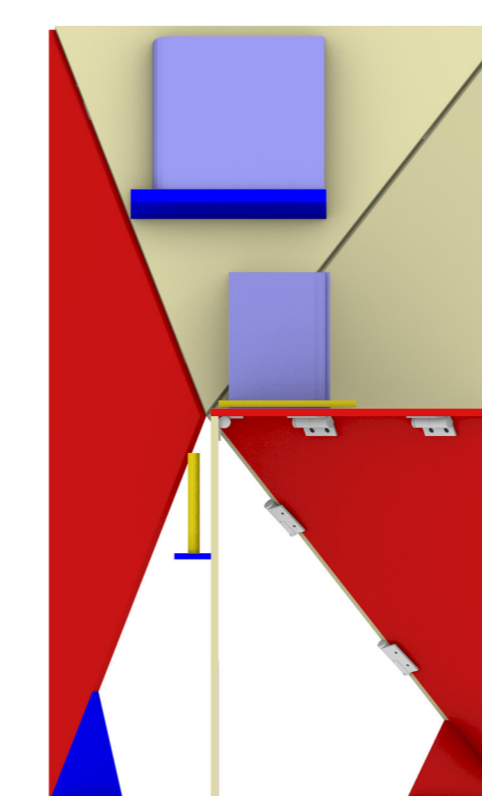
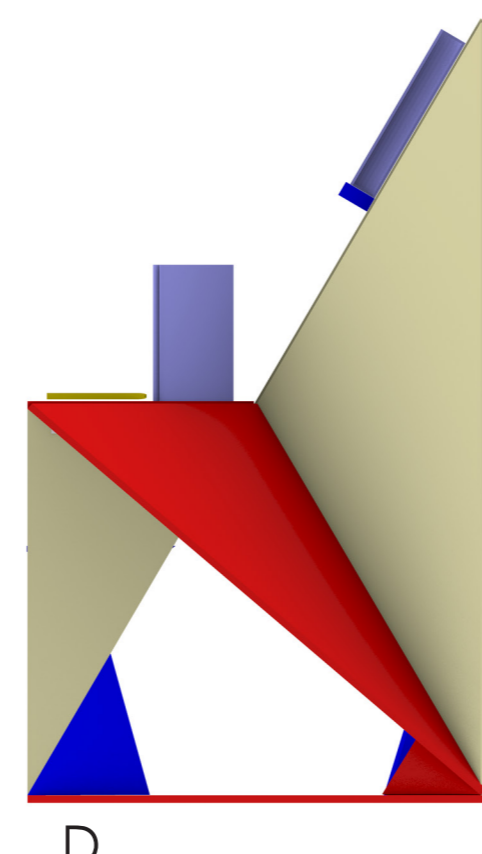

B

Elevations
1:10

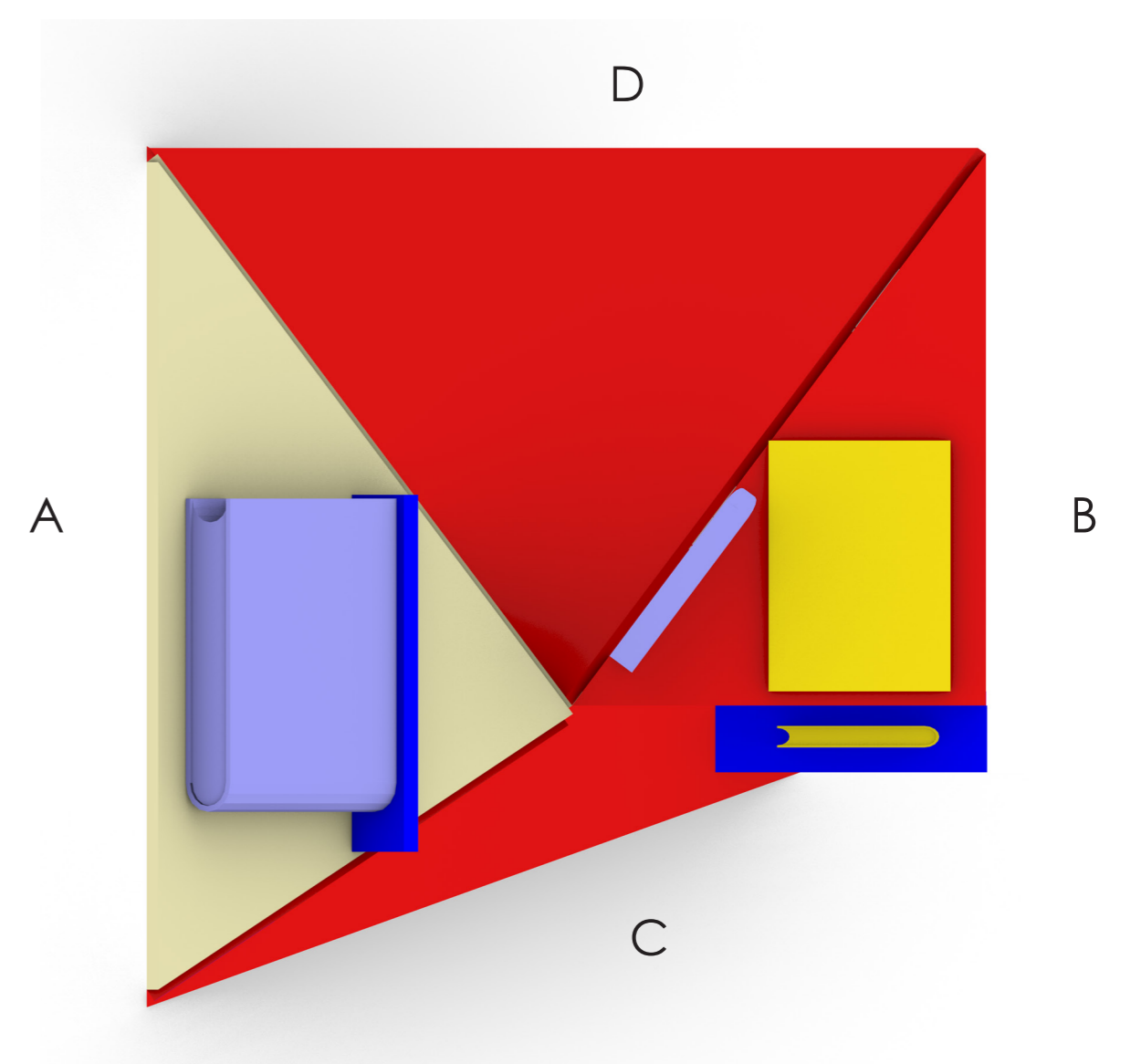

Vue aérienne
1:5